

NOTES:

1. INLET & OUTLET: 1/2" MNPT
2. SUCTION PORT: 1/4" (ID) TUBING BARB SHANK OR 1/4" MNPT
3. MATERIAL OF CONSTRUCTION: GLASS REINFORCED POLYPROPYLENE OR PVDF (KYNAR)
4. MAXIMUM TEMPERATURE RATING:
 - POLYPROPYLENE: 150 F. (65.5 C.)
 - PVDF: 200 F. (93.3 C.)
5. MAXIMUM PRESSURE RATING AT 68 F. (20 C.)
 - POLYPROPYLENE: 150 PSIG (10.3 BAR)
 - PVDF: 200 PSIG (13.8 BAR)

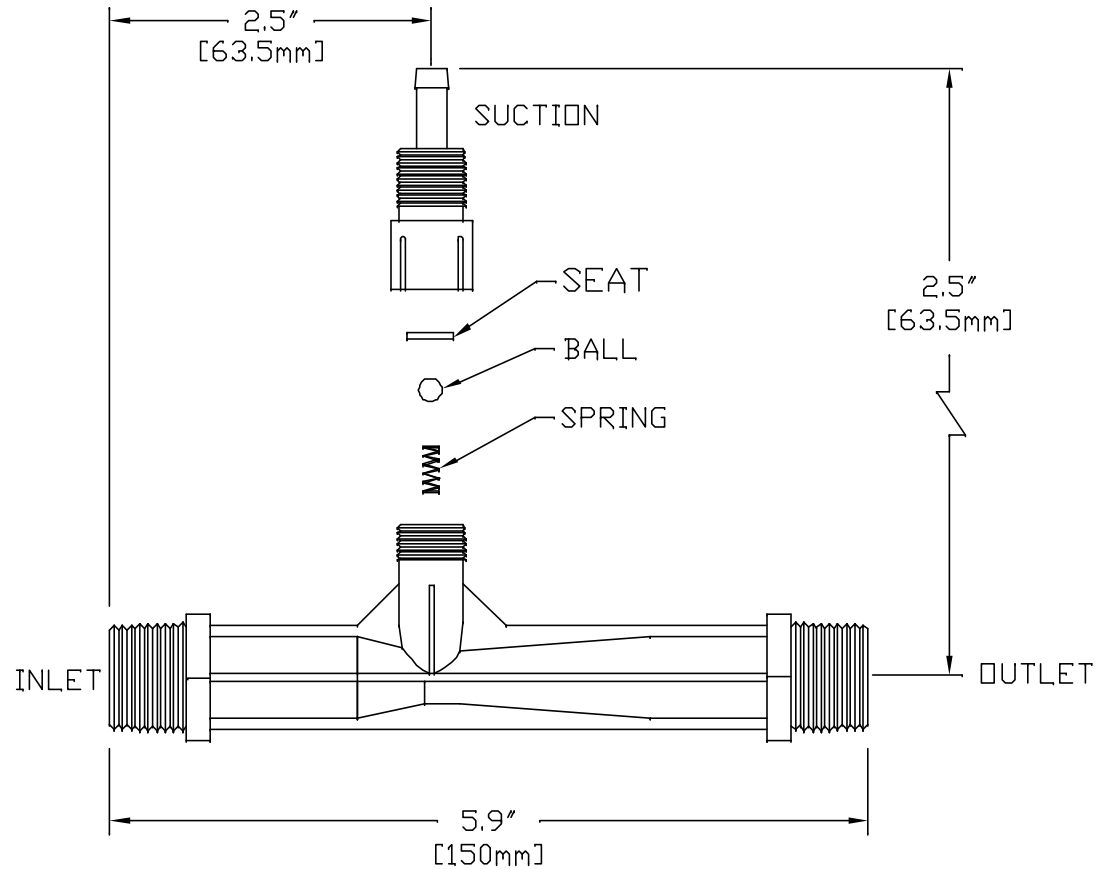

Covered By United States Patent No. 5,863,128
International Patents Pending



Mazzei Injector Company, LLC
500 Rooster Drive, Bakersfield, CA 93307
Tel: 661.363.6500 Fax: 661.363.7500

DATE	12-14-00	TITLE		
DRAWN BY	JRM	MODEL 384-X INJECTOR		
REVIEWED BY	RST	NUMBER	JRM-7	SIZE
SCALE	NONE			REV.
MATERIALS: SEE NOTES		PAGE (1) OF (1)		